

Step 1: Parts

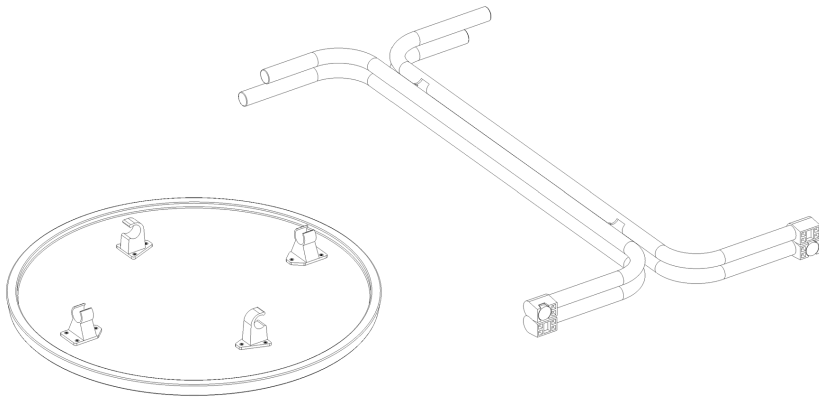

Step 2: Put the table top with the top side down on the floor (*). When the short tubes are aligned with the plastic parts, press firmly downwards so the long tubes will slip into the plastic holders.

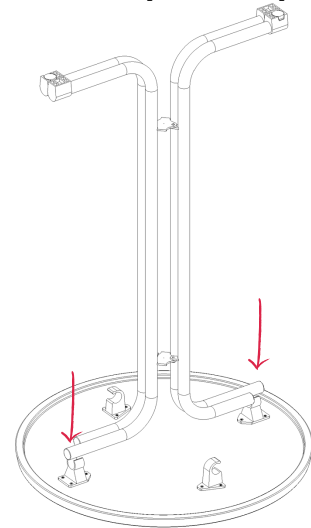

Step 3: Rotate the other two tubes 90 degrees and insert them into the other two holders.

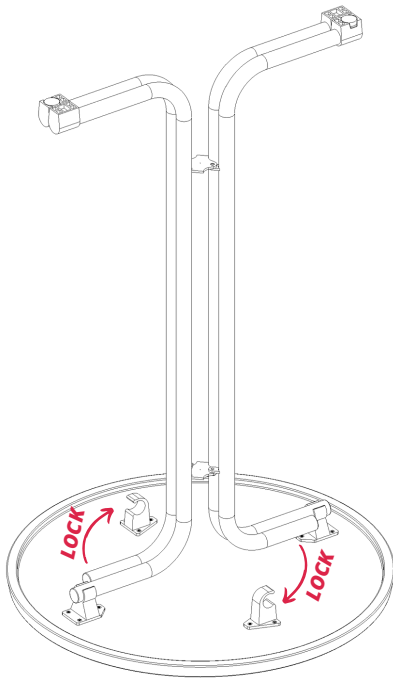

Step 4: Turn the table and put it on its legs.

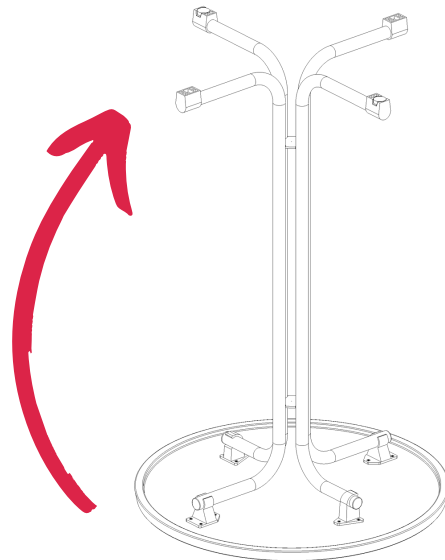

Step 5: Your table is ready to use!

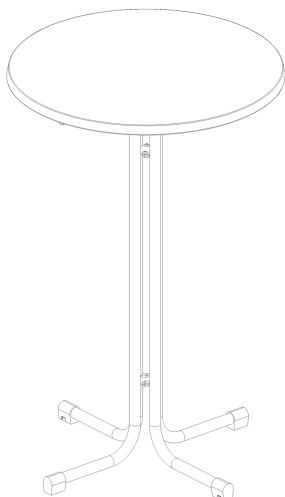

Step 6: Transport or storage: Unplug the two shortest sides from the holders and turn them back 90 degrees against the longer legs. Afterwards, fold the table.

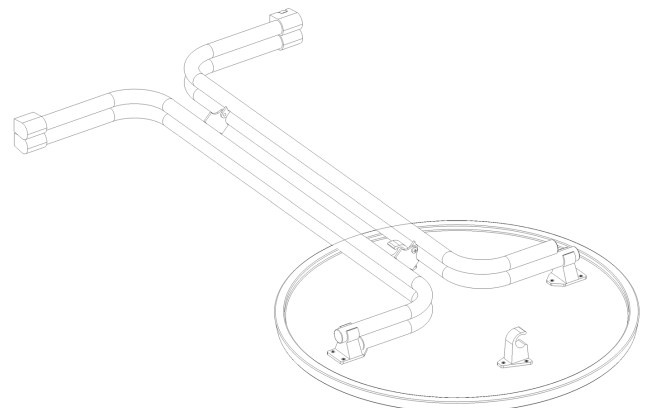

***Perform the assembly carefully to avoid damage to the table top/frame.**